

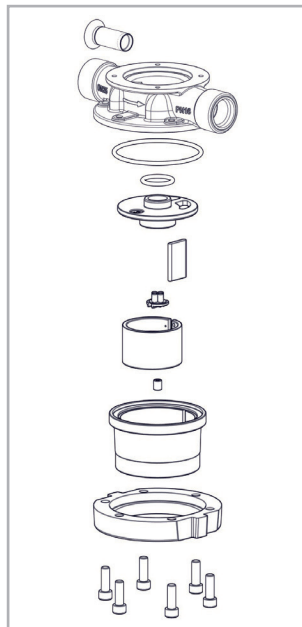

## CONTOIL®

Fuel oil meters  
DN 15...50

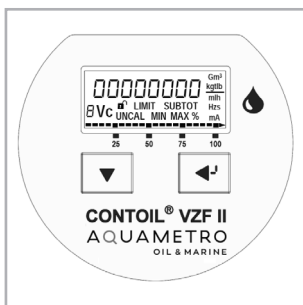
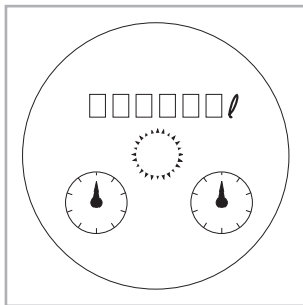

A versatile flow meter for oil, heavy oil and many other oil-like liquids. It is used for efficient consumption measurement of heat burners and various combustion engines. A reliable solution for any application where oil is consumed.

### Features

- State-of-the-art design
- Electronic counter, Mass flow, volume flow indication, analog, multiple output signals
- Integrated temperature sensor
- No straight inlets or outlets required
- Independent of viscosity and temperature
- High vibration resistance
- Optional: metrological type approvals
- Auto Medium switch over by temperature

### Benefits

- Mass flow measurements
- Highly flexible mounting with very small space requirements
- Reliable monitoring and flexible control of the system
- Accurate measurements
- A reliable solution with everything from a single supplier
- Simplifies consumption optimizing

## Product range CONTOIL® DN 15...50

### CONTOIL®

Hydraulic



### one hydraulic with multiple read out options

Housing with threaded or flanged connections

Main characteristics:

- optimal flow range 10...30 000 l/h
- temperature ranges 130 and 180 °C
- nominal pressure PN 16 and 25 bar (PN 40 on request)

Page 7

### CONTOIL® VZF/A II

Electronic read out



### with multifunctional display and adjustable outputs

Electronic display of:

- totalizer, total, resettable volume, mass and temperature
- actual flow rate
- other flow parameters

Output signals for:

- volume and mass pulses
- actual flow rate and mass flow
- limiting values (Qmin, Qmax)
  
- simple to operate
- interactive parameter input
- external power supply (4...20 mA loop powered)

Page 8

## CONTOIL® VZO/A

Mechanical read out



## total volume display

Total volume display on roller counter

[Page 10](#)

## CONTOIL® VZO/A RV/IN

Mechanical read out

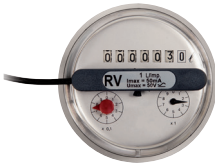

## total volume display and remote transmission

Total volume display on roller counter with Reed pulse RV for remote totalization



Inductive IN pulse for control purposes

[Page 10](#)

## CONTOIL® DFM

Blind unit



## compact design for remote display transmission

Pulse value for remote totalizing

[Page 12](#)

## CONTOIL® CE MID

Conformity approved read out

## for verified applications where an approved measurement system is required

[Page 14](#)

# Content

<b>Introduction</b>	<b>4</b>
<b>Operating principle</b>	<b>5</b>
<b>Technical specifications</b>	<b>7</b>
<b>Project planning notes</b>	<b>21</b>
<b>Installation</b>	<b>25</b>
<b>Display and user interface</b>	<b>28</b>
<b>Warranty, safety instructions</b>	<b>29</b>
<b>Certificates</b>	<b>30</b>

## Introduction

Thank you for your decision to work with Aquametro Oil & Marine AG Fuel Performance Products. This technical specification describes the installation, commissioning and use of CONTOIL® Fuel Meters. For additional information please contact your local sales agent at: [www.aquametro-oil-marine.com](http://www.aquametro-oil-marine.com).

### Liability Disclaimer

The manufacturer cannot monitor the compliance to this manual as well as the conditions and methods during the installation, operation, usage and maintenance of the system regulator.

Improper installation can cause damages and endanger people. Therefore, we assume no responsibility and liability for losses, damages or costs that result due to incorrect installation, improper operation, usage and maintenance or in any manner associated therewith. Similarly, we assume no responsibility for patent right or other right infringements of third parties caused by usage of this system regulator.

The manufacturer reserves the right, without prior notification, to make modifications concerning the product, technical data or installation and operating manual.

### Safety precautions

CONTOIL® flow meters must only be used for their intended purpose and comply with local and international safety regulations. All documentation is to be followed exactly. None of the information stated here or elsewhere releases planners, installers and operators from their own careful and comprehensive assessment of the respective plant configuration in terms of functional capability and operational safety.

- Local applicable working regulations must be complied with, during all work on the plant and/or ship.
- All safety-, installation- and operation instruction as described in this manual must be followed.
- Sensors are sensitive measuring instruments and should be treated carefully.

# Operating principle

## Function

CONTOIL® flow meters work on the volumetric principle of rotary piston meters (positive displacement meters).

The main features of this measuring principle are large measuring ranges, high accuracy, suitability for high viscosities and independence from power supply; flow disturbances do not influence proper operation.



Leading manufacturers of oil burners and operators of heating systems, ships or diesel engines rely on CONTOIL® fuel oil meters - and with good reasons.

## The advantages of CONTOIL® fuel oil meters - your benefits

- Optimal solution for every application
- Mass flow measurement (VZF II types)
- Integrated temperature sensor (VZF II types)
- Simple burner setting with flow rate display (VZF II types)
- Simple consumption monitoring with limiting value switch  $Q_{min}/Q_{max}$  (VZF II types)
- Manual dosing feature, with a resettable counter (VZF II types)
- Can be mounted on the pressure or suction side of a pump
- Space-saving installation, because no straight inlet/outlet sections are required
- Flexible mounting of the meter in horizontal, vertical or inclined positions
- Accurate measurement result, since the reading is independent of the temperature and viscosity of the fluid
- Minimum failure costs due to simple function monitoring, rapid fault analysis and the possibility of simple repairs on site

## Areas of application

- To measure heating fuel consumption by oil burners (for example, in heating boilers, industrial furnaces, tar processing plants)
- Consumption monitoring and optimisation (ships, generators, etc)
- Flow measurement for mineral oils
- Optional remote processing and integration into superior systems
- Manual dosing / batching

## Fuel types

- Fluids according to ISO 8217-2010
- Heating fuel extra light / light, medium, heavy, fuel blends
- Naphtha
- Lubricating liquids (oils)

## Type key

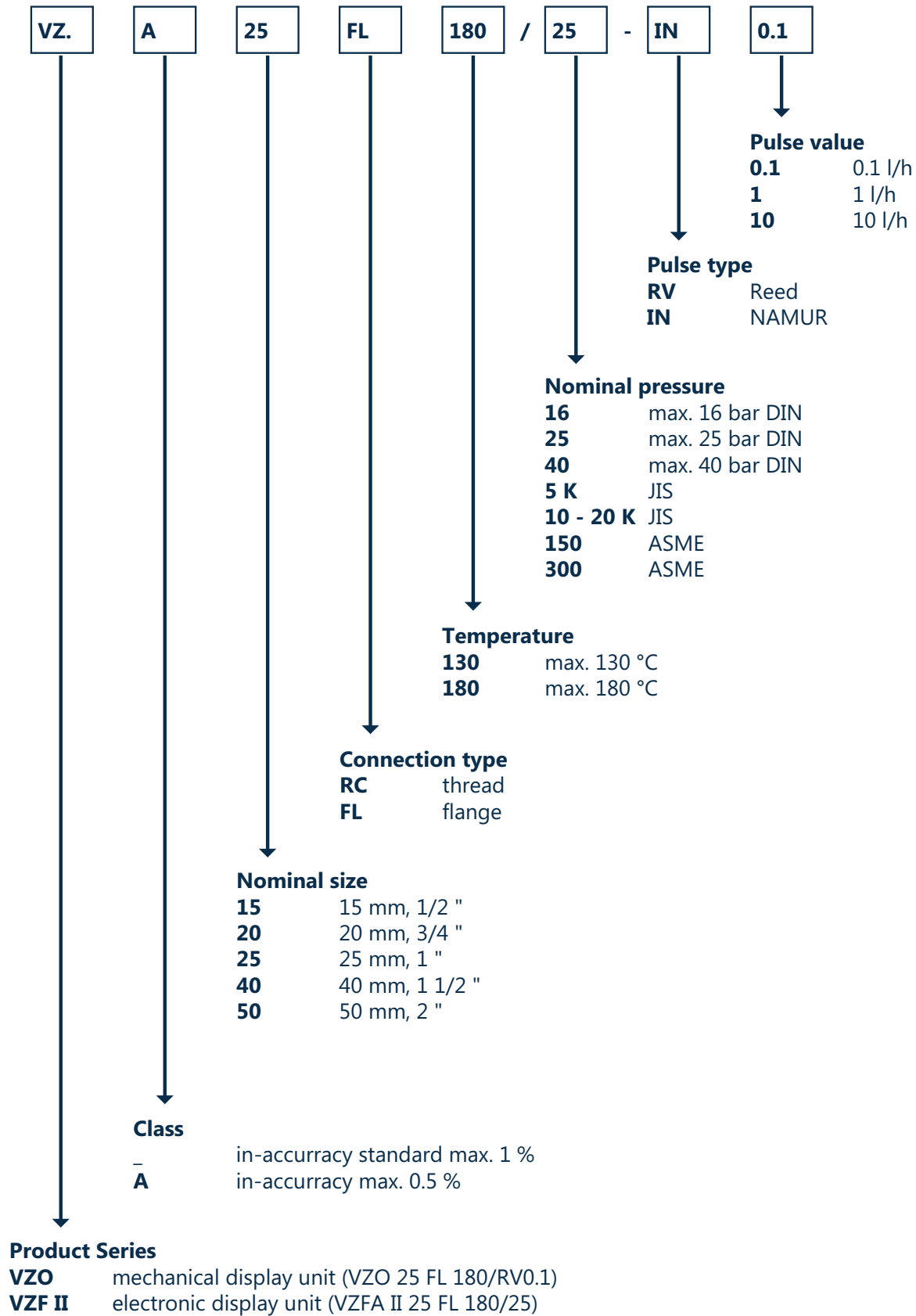

# Technical specifications

## Technical data CONTOIL® DN 15...50 Hydraulic



Hydraulic		Meter DN size					
Nominal diameter	DN mm	15	20	25	40	50	
	inch	1/2	3/4	1	1 1/2	2	
Installation length	mm	165	165	190	300	350	
Nominal pressure threaded ends	PN bar	16					N/A
Nominal pressure flanges	PN bar	25 / 40					
Maximum flow rate	Qmax <sup>2)</sup> l/h	600	1500	3000	9000	30000	
<b>Continuous flow rate</b>	<b>Qcont <sup>2)</sup> l/h</b>	<b>400</b>	<b>1000</b>	<b>2000</b>	<b>6000</b>	<b>20000</b>	
Minimum flow rate	Qmin l/h	20	40	75	225	750	
Approx. starting flow rate	l/h	4	12	30	90	300	
Max. permissible error <sup>1)</sup>	(VZF II/VZO/DFM)	<±1.0 % of actual value					
	(VZFA II/VZOA)	<±0.5 % of actual value					
	VZFA II linearized	<±0.3 % of actual value					
Repeatability		<±0.1 %					
Measuring chamber volume	cm <sup>3</sup>	12	36	100	330	1200	
Safety filter mesh size	mm	0.400	0.400	0.400	0.800	0.800	
Weight with threaded ends <sup>3)</sup>	kg	2.2	2.5	4.2	17.3	-	
Weight with flanges PN 25	kg	3.8	4.5	7.5	20.3	41.0	
Weight with flanges PN 40	kg	4.4	5.5	7.8	20.5	42.0	
Hydraulic Material		Meter DN size					
Part	Material	DN mm	15	20	25	40	50
Housing with threaded ends	Cast Brass		■	■	■		
	Spheroidal graphite iron GJS 400-15					■	
Housing with flanged ends	Spheroidal graphite iron GJS 400-15		■	■	■	■	■
	Cast Brass		■	■	■	■	
Measuring chamber PN 16 / 25	Alu-Bronze						■
	Stainless steel		■	■	■	■	■
Measuring chamber PN 40							■
Seals	FPM fluorelastomer		■	■	■	■	■
Rotary piston	Anodized aluminium		■	■	■	■	■
Ancillaries	Plastic		■	■	■	■	■
Housing finish	Enameled red, RAL 3013		■	■	■	■	■

<sup>1)</sup> Manufacturer's specification, valid for the reference conditions as specified under Reference conditions.

<sup>2)</sup> For burners and engines or motors, the meter must be selected on the basis of the permanent flow rate. For higher viscosities, or if the meter is installed on the suction side, the pressure drop and any reduction in the measuring range must be taken into consideration.

<sup>3)</sup> Weight without couplings.

## Technical data CONTOIL® VZF/A II Electronic display



Electronic display		Meter DN size					
Nominal diameter		DN mm	15	20	25	40	50
		inch	1/2	3/4	1	1 1/2	2
Max. medium temperature	Tmax	°C	130, 180				
Max. environment temperature		°C	-25...+70				
Max. storage temperature	Tmax	°C	-25...+85				
Max. storage humidity	rhmax	% rh	95, non condensing				
Total volume / mass		l, m <sup>3</sup> , G <sup>1)</sup> , kg, t, lb	max. 3 decimals (dynamic)				
Resettable volume / mass		l, m <sup>3</sup> , G <sup>1)</sup> , kg, t, lb	max. 3 decimals (dynamic)				
Flow rate			max. 3 decimals (dynamic)				
Smallest readable amount			0.001				
Maximum registration capacity			8 digits				
Registration time until overrun	Qcont (m <sup>3</sup> )		>100 years				
<b>Electronic</b>							
Supply voltage		VDC	6...30				
Quiescent current		A	4mA				
Solid state relay (out1 & out2)							
Resistance ON		Ohm	≤100				
Resistance OFF		MOhm	≥10				
Max. Supply voltage Umax		VAC/VDC	≤48				
Switching current Imax		mA	≤50				
Pulse width		ms	2...500				
Pulse frequency		Hz	0...200				
<b>Outputs</b>							
Three (2 pulse/freq., 1 4...20 mA)			freely selectable, totally independent of each other				
Pulse value totalizer			volume or mass pulse 0...200 pulse/sec. (50 % duty cycle)				
Current 4...20 mA for flow			volume flow, mass flow or temperature signal to 4 and 20 mA				
Frequency for flow	Qmin, Qmax		minimum, maximum and hysteresis parameterized				
State switch	Alarm, Error		state and on/off parameterized				

<sup>1)</sup> 1 US gallon corresponds to 3.785 liters.



# Electronic counter CONTOIL® VZF/A II

Local electronic display with multiple output.

Display unit with coupling and temperature sensor

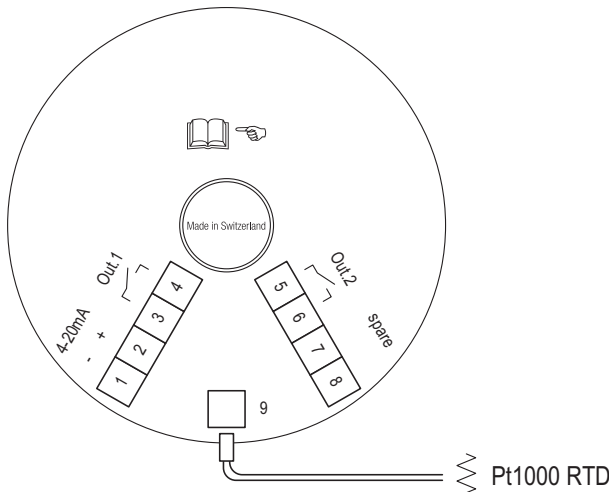
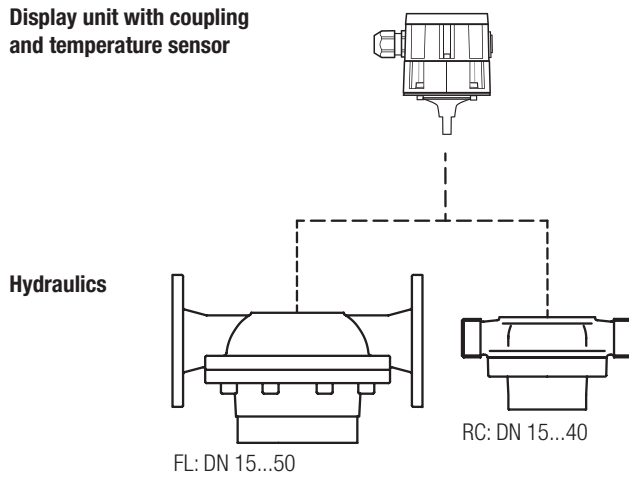

Sensor area! (Sensor dome)  
No cables, wires or other installation material must be present in this area. This can lead to incorrect measurements and damage to the meter.

1 / 2 power supply and analog current signal output  
3 - 6 Output 1 and 2  
Wire size for terminal 1 - 6 is: 0.75...1.5 mm<sup>2</sup> / 20...16 AWG

## Factory setting of outputs

Output 1: Volume pulses: 50 ms, 1 ltr/pulse (exception: DN 15 is set to 0.1 ltr/pulse)  
Output 2: Volume pulses: 50 ms, 1 ltr/pulse (exception: DN 15 is set to 0.1 ltr/pulse)  
Analog: disabled (off)

## Engineering notes

The maximum frequency is calculated with the following formula:

$$\frac{\text{max.flow rate in liters/hour}}{\text{pulse value in liters} \times 3600} = \text{frequency in Hz} \leq 200 \text{ Hz}$$

## Technical data CONTOIL® VZO/A Mechanical display



Mechanical display		Meter DN size				
Nominal diameter	DN mm	15	20	25	40	50
	inch	1/2	3/4	1	1 1/2	2
Smallest readable amount	l	0.01	0.1	0.1	0.1	1
Maximum registration capacity	m <sup>3</sup>	1000	10000	10000	10000	100000
Registration time until overrun Qcont (m <sup>3</sup> )	h	2500	10000	5000	1667	5000
Electronic REED Sensor						
Supply voltage	VDC	6...30				
Ambient temperature	°C	-10...+70				
Switching element Reed contact						
Switching voltage max.	DC/AC	48 V				
Switching current max.	mA	50 (Ri 47Ω)				
Breaking capacity max.	W	2				
Quiescent current zero						
Pulse value see type plate						
Pulse width	ms	2...500				
Pulse frequency	Hz	0...200				
RV Reed	l/pulse	0.1	1	1	1	10
RV Reed	l/pulse	1			10	100
Electronic IN Sensor						
Supply voltage	VDC	5...25				
Ambient temperature	°C	-10...+70				
Switching element slot initiator acc. to IEC 60947-5-6 (NAMUR)						
Switching voltage max.	DC	5 – 15 V				
Residual ripple		< 5 %				
Switching current	mA	> 3 (at 8 V, 1 kΩ)				
Quiescent current zero	mA	< 1 (at 8 V, 1 kΩ)				
Pulse value see type plate						
Pulse width	ms	2...500				
Pulse frequency	Hz	0...200				
Pulse values for remote transmitter						
IN inductive (IEC 60947-5-6)	l/pulse	0.01	0.01	0.1	0.1	1

## Mechanical counter CONTOIL® VZO/A

Local mechanical display with or without pulse output.

### Display units

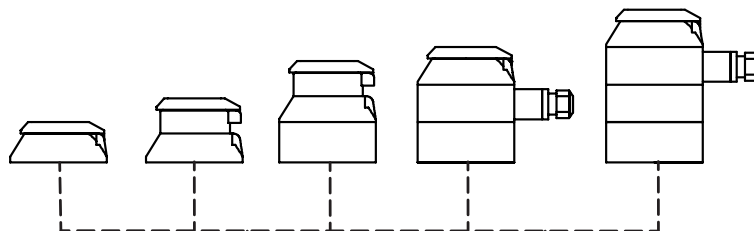

### Hydraulics

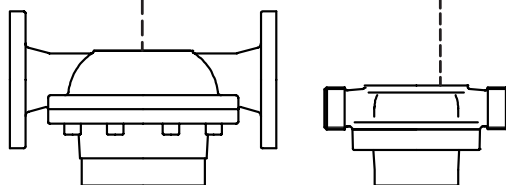

FL: DN 15...50

RC: DN 15...40

### Pulser RV

- Pulse value is marked on type plate
- Cable: 3 m
- Polarity: in any order

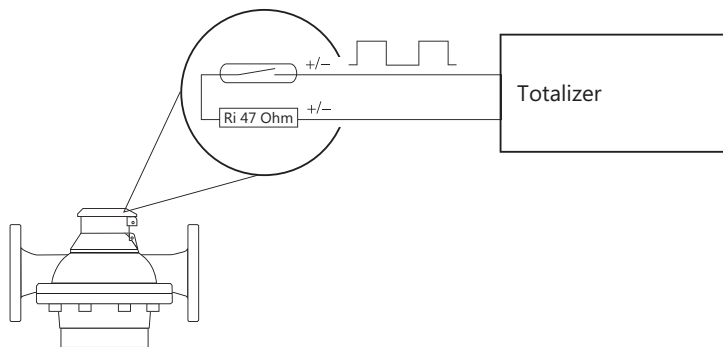

### Pulser IN

Pay attention to polarity when connecting the plug.

- Pulse value is marked on type plate
- Connection cable min. 2 x 0.35 mm<sup>2</sup> and 5.5 - 13 mm external cable diameter on plug
- Prefabricated cable available

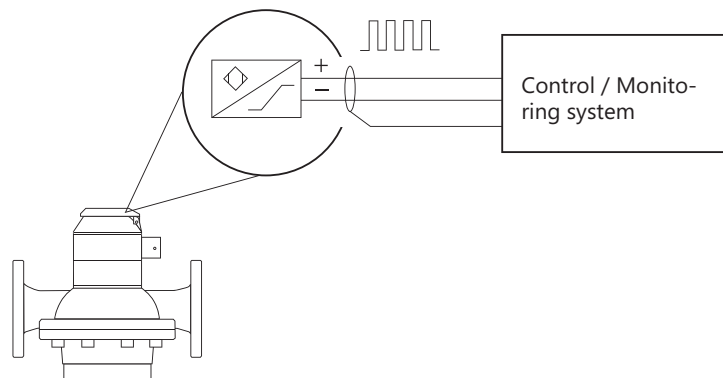

## Technical data CONTOIL® DFM Blind unit

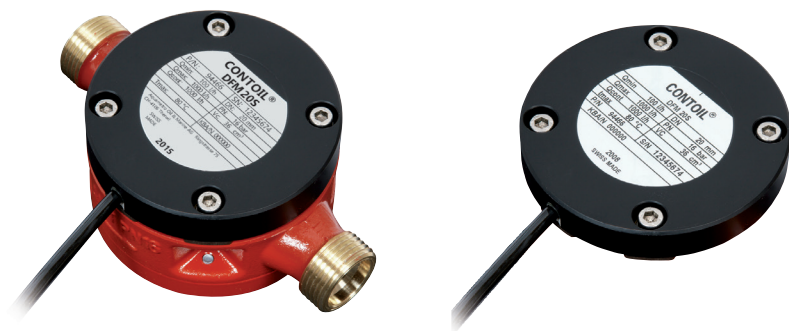

DFM blind unit		Meter DN size	
Nominal diameter	DN mm	20	25
	inch	3/4	1
Electronic			
Supply voltage	VDC	6...32	
Pulse width	ms	20	
Operating temperature	°C	-20...+ 80	
Storage temperature	°C	-40...+125	
Switching element		Open Drain	
Supply voltage	VDC	12/24 board systems	
Switching voltage max.	DC/AC	48 V	
Switching current max.	mA	50	
Pulse value see type plate			

## Options for CONTOIL®

### Pairing

If the application consists of a differential measurement (supply and return), the CONTOIL® VZFA II or VZOA can be paired with higher accuracy.

The flow is measured in the supply and return line pipes. The difference between the two measurements is regarded as the consumption.

To obtain optimal measurement results, CONTOIL® VZFA II or VZOA fuel oil meters are calibrated in pairs, they are adapted precisely to the plant/system operating conditions. The flow rate occurring in each meter, the permissible pressure drop and the viscosity of the fluid must all be considered during the design phase.

The pairing range of the flow meters is obtained as follows:

Flow in supply section less maximum consumption = flow in return section.

When the order is placed, the following additional information is required:

- flow rate in supply section e.g. fixed pumping rate 200 l/h
- flow rate in return section e.g. 120...190 l/h (consumption of 10...80 l/h)

The meters are marked "supply" and "return" during calibration and final testing in the factory. They must then be installed in the designated location. For further information on the subject of differential measurement, see the section "Project planning notes".

### Linearization

The CONTOIL® VZFA II can be linearized to achieve an even better accuracy of +/-0.3 % across the full measuring range (Qmin...Qmax). During this calibration process the flow meter is being tested across the full range with a maximum of 15 measuring points and then linearized and tested.

### Reference conditions

Measuring error limits according to technical data of meter in % of actual value for the whole measuring range.

Calibration medium: Calibration oil is similar to extra light heating oil, density at 20 °C = 814 kg/m<sup>3</sup>

Viscosity = 5.0 mm<sup>2</sup>/s according to DIN 51757 / ISO 3104 (corresponds to 4.1 mPa.s)

Temperature: 18...25 °C

Horizontal mounting, readings from counter.

CONTOIL® oil meters are never to be tested with water, otherwise they will get damaged.

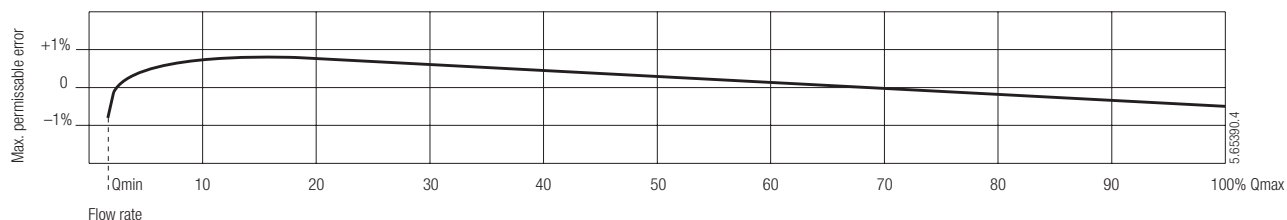

## Technical data CONTOIL® DN 15...50 - VZFA II CE and VZOA CE



Hydraulic			Meter DN size				
Nominal diameter	DN mm		15	20	25	40	50
	Inch		1/2	3/4	1	1 1/2	2
Installation length	mm		165	165	190	300	350
Nominal pressure threaded ends	PN bar		16				
Nominal pressure flanges	PN bar		25				
Max. medium temperature	Tmax	°C	130				
Max. environment temperature	T	°C	-25...+70				
Max. storage temperature	Tmax	°C	-25...+85				
Max. storage humidity	rhmax	%rh	95, non condensing				
Maximum flow rate	Qmax	l/h	400	1000	2000	6000	20000
Minimum flow rate	Qmin	l/h	40	100	200	600	2000
Minimum measured volume	Vmin	l	2	20	20	20	200
Max. permissible error <sup>1)</sup>	(VZFA II CE / VZOA CE)		< ±0.3 % of actual value				
Accuracy class			0.5				
Measuring chamber volume	cm <sup>3</sup>		12	36	100	330	1200
Safety filter mesh size	mm		0.400	0.400	0.400	0.800	0.800
Weight with threaded ends <sup>2)</sup>	kg		2.2	2.5	4.2	17.3	-
Weight with flanges PN 25	kg		3.8	4.5	7.5	20.3	41.0
Hydraulic Material			Meter DN size				
Part	Material	DN mm	15	20	25	40	50
Housing with threaded ends	Cast Brass		■	■	■		
	Spheroidal graphite iron GJS 400-15					■	
Housing with flanged ends	Spheroidal graphite iron GJS 400-15		■	■	■	■	■
Measuring chamber PN 16 / 25	Cast Brass		■	■	■	■	
	Alu-Bronze						■
Measuring chamber PN 40	Stainless steel		■	■	■	■	■
Seals	FEP fluorelastomer		■	■	■	■	■
Rotary piston	Anodized aluminium		■	■	■	■	■
Ancillaries	Plastic		■	■	■	■	■
Housing finish	Enameled red, RAL 3013		■	■	■	■	■

<sup>1)</sup> Manufacturer's specification, valid for the reference conditions as specified under Reference conditions.

<sup>2)</sup> Weight without couplings.

Mechanical and electronic display units are available as described previously.

## Technical data CONTOIL® DN 15...50 - VZFA CE II and VZOA CE

### Versions with type approval or calibration verification

These flow meters bear the test number for the metrological type test certificate in accordance with directive 2014/32/EU and the metrological CE mark and are therefore suitable for custody transfer. For custody transfer, the meters can only be used for direct consumption measurement and has to be installed between fixed pipes. The measurement result can be transferred to external meters by means of pulse transmitters or pulse outputs. The transferred measurement result is not in line with the directive 2014/32/EU and cannot be used as a legally displayed result. Only the local display of the flow meter is valid for custody transfer.

### Area of use

The CONTOIL® flow meter with MID approval is used almost exclusively where the measured liquid (heating oil, diesel) then goes directly to the consumer (heating system burner). Other applications than the described above, must be checked and approved by the local authorities.

In accordance and compliance with the applicable norms for custody transfer, CONTOIL® flow meters with MID approval can be used.

### Responsibility

Installation, operation, maintenance and decommissioning of this device must be carried out by trained, qualified specialists, authorized by the manufacturer, operator or owner of the facility.

### Pump operation

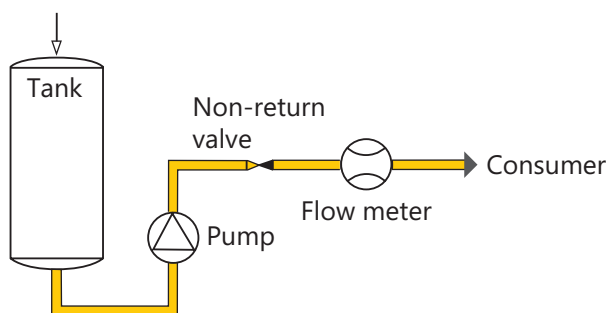

### Hydrostatic operation

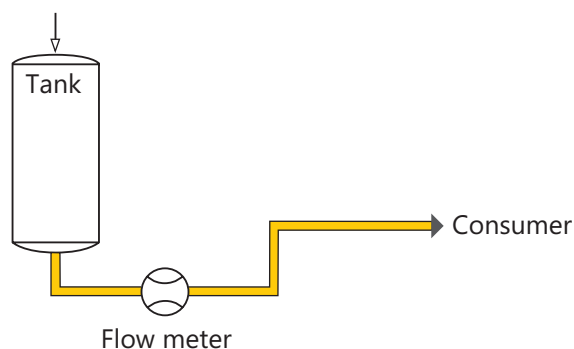

### Burner

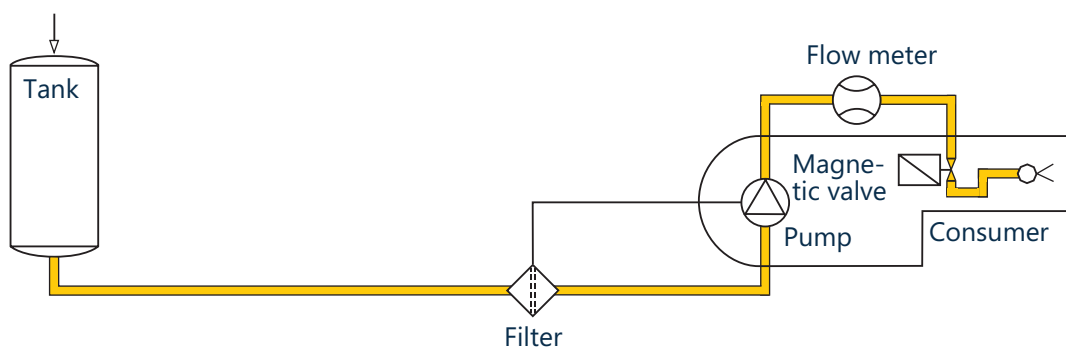

### Wrong installation!

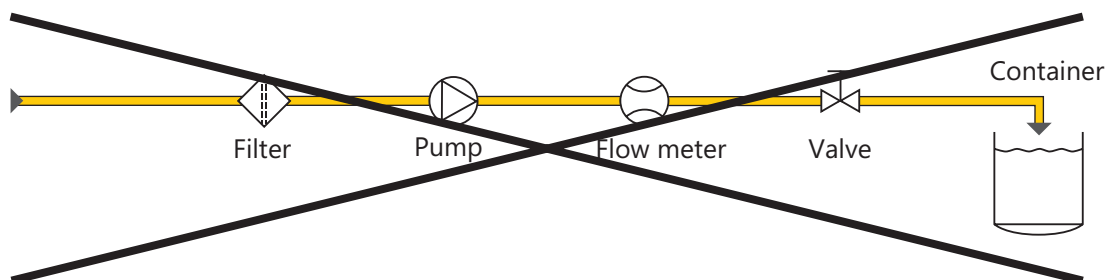

## Dimensional drawings

All flow meters with threaded ends are according to ISO 228-1.

DN 15, 20, 25: with threaded ends

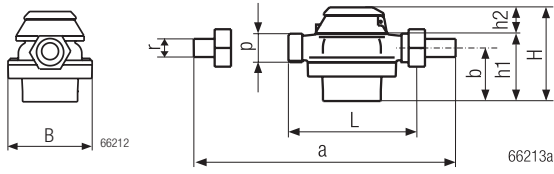

DN 40: with threaded ends

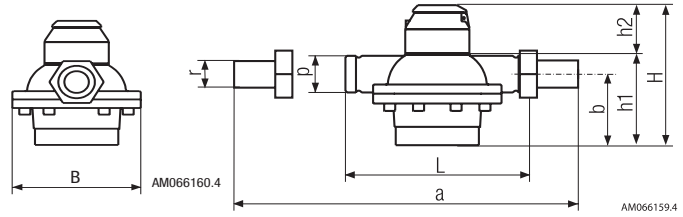

All flow meters with flanges are according to EN 1092-2, ASME B16.5 or JIS B2220.

DN 15, 20, 25: with flanged ends

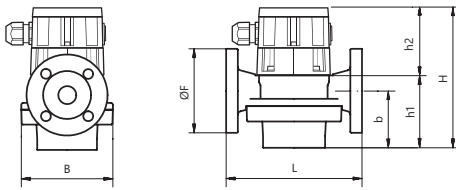

DN 40, 50: with flanged ends

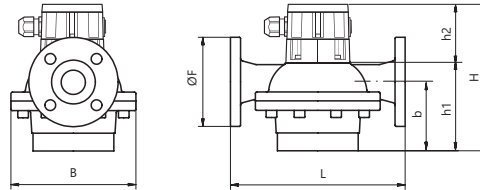

Nomial size	L	B	a	Ø F	b	h1	p	r
DN 15	165	105	260	95	45	65	G 3/4"	G 1/2"
DN 20	165	105	260	105	54	74	G 1"	G 3/4"
DN 25	190	130	305	115	77	101	G 1 1/4"	G 1"
DN 40	300	210	440	150	116	153	G 2"	G 1 1/2"
DN 50	350	280	-	165	166	209	-	-

Dimensions in mm

h2 is explained on next page

H = h1 + h2



## Dimensions of display and pulse units

Sensor	VZF(A) II*	VZO 15...50*						VZO 40...50 / VZOA*					
Max. temperature	130/180 °C	130 °C			180 °C			130 °C			180 °C		
Pulsers	all	-	RV	IN	-	RV	IN	-	RV	IN	-	RV	IN
Dimensional drawing	1	2	3	6	5	4	7	2	3	6	5	4	7

\* VZF(A) II, VZO(A): Dimensional drawings (h2) 1 - 7 from table

1

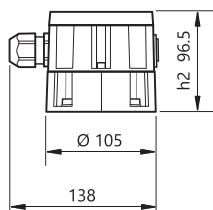

2

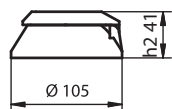

3

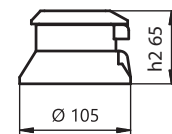

4

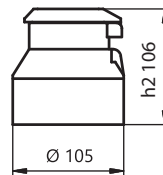

5

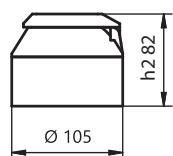

6

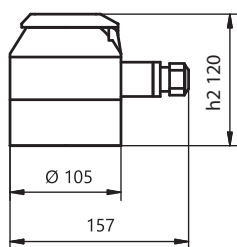

7

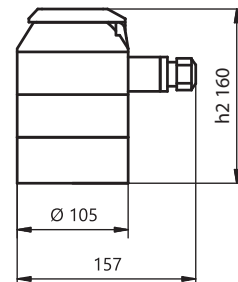

VZF II / VZFA II

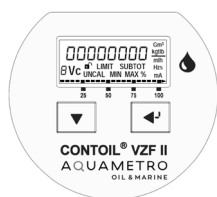

VZO / VZOA 15

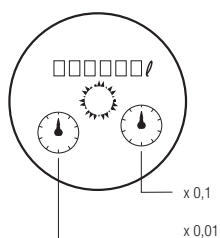

VZO / VZOA 20, 25, 40

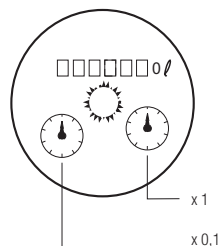

VZO / VZOA 50

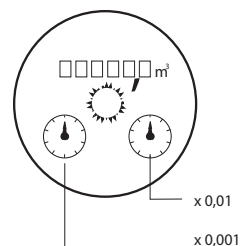

AM06607.4

# Pressure drop curves

## DN 15

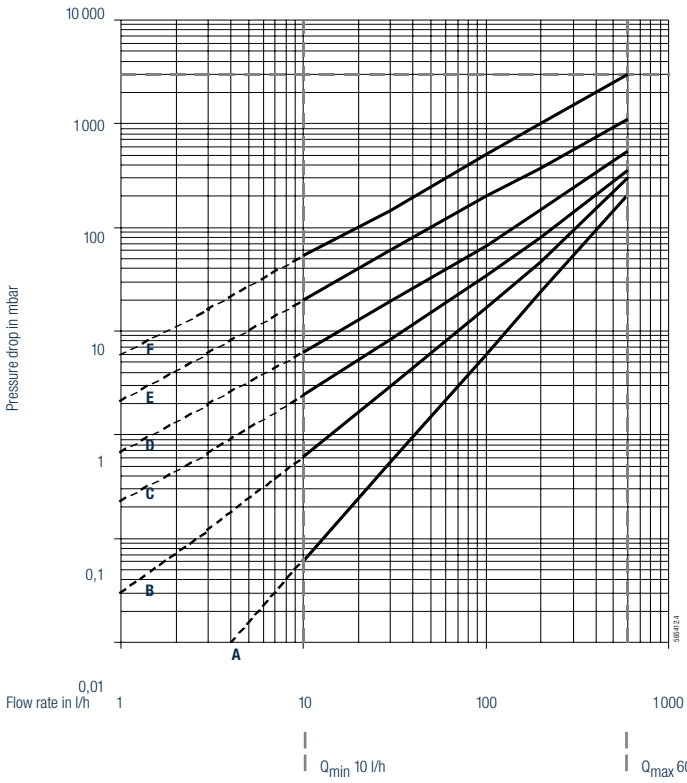

## DN 20

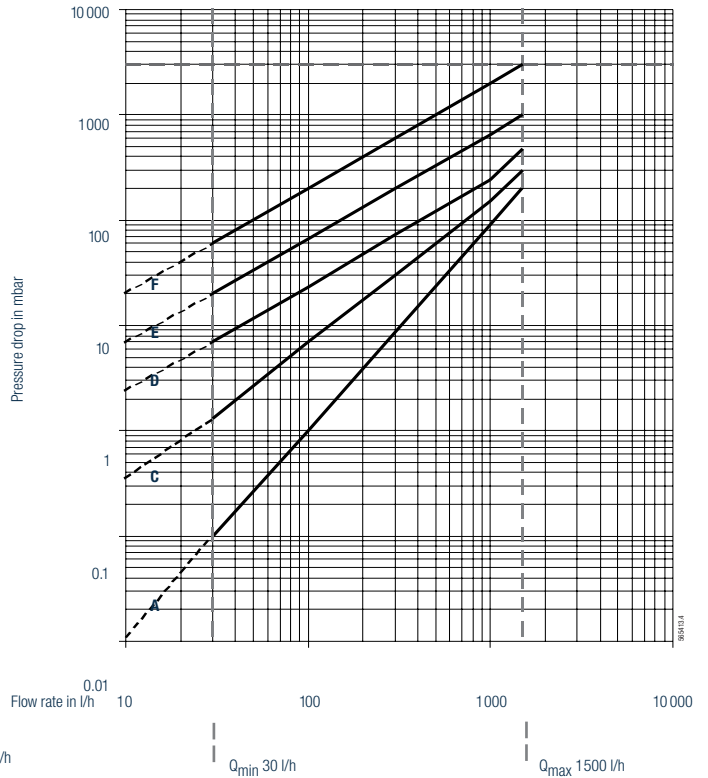

## DN 25

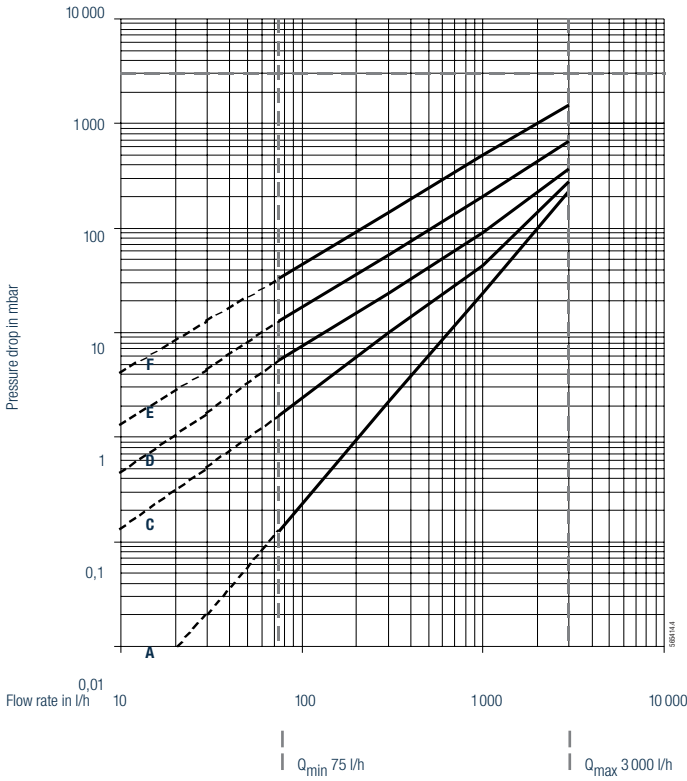

## DN 40

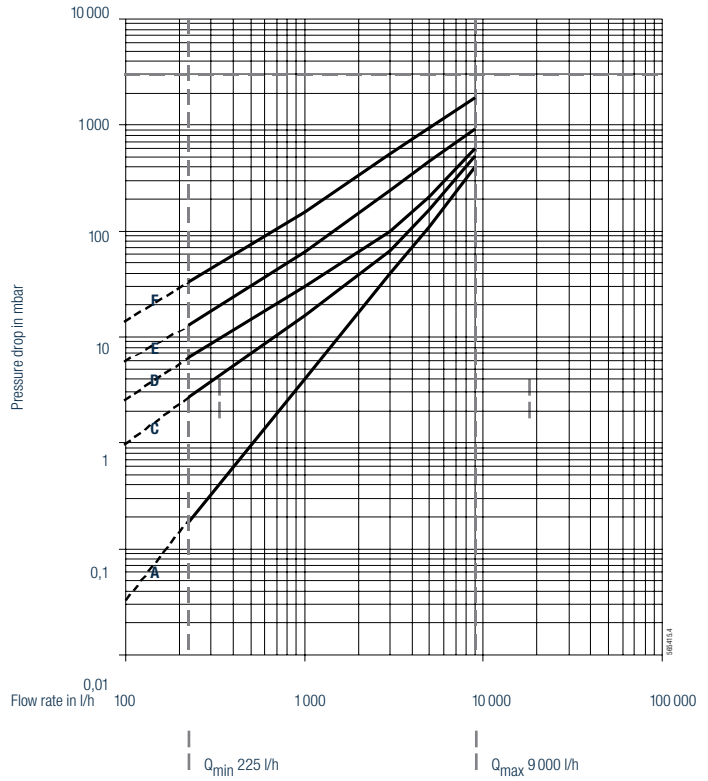

Viscosity diagrams: A = 5 mPa.s    C = 50 mPa.s    E = 200 mPa.s  
 B = 25 mPa.s    D = 100 mPa.s    F = 500 mPa.s

For a pressure drop of more than 1 bar, it is recommended to use the next larger meter size.  
 Maximum permissible pressure drop = 3 bar

## DN 50

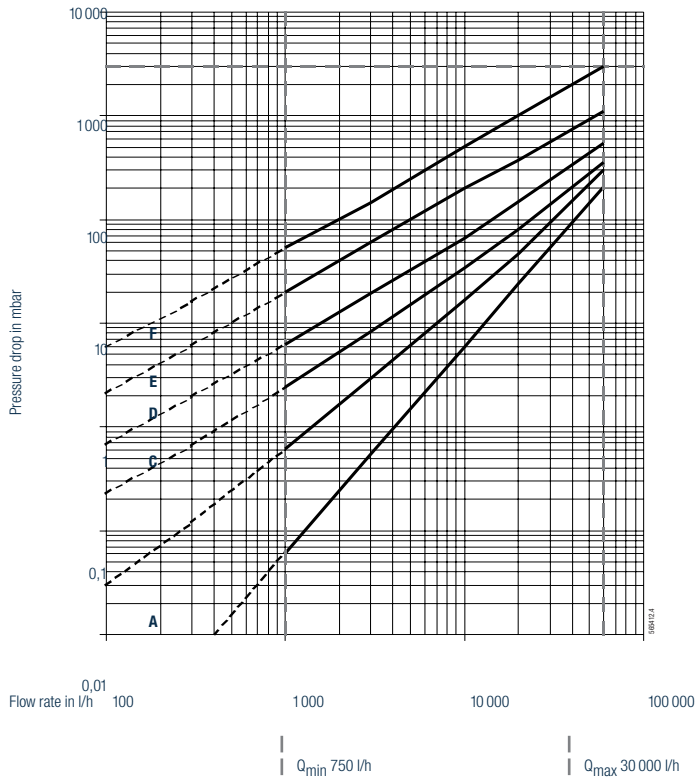

### Example

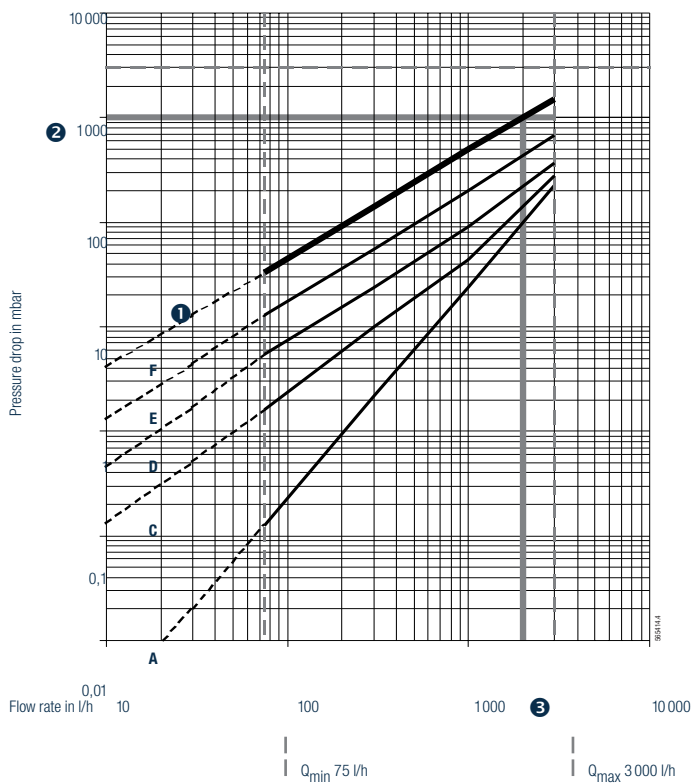

Mineral oil, viscosity 450 mPa.s  
VZO 25 mounted on pressure side of pumps

- ① Viscosity curves DN 25  
select closest curve  
F = 500 mPa.s
- ② Assume max. permissible pressure drop  
= 1 bar
- ③ The intersection of curve F with the line  
corresponding to 1bar gives a flow rate  
of 2000 l/h.

## Parts

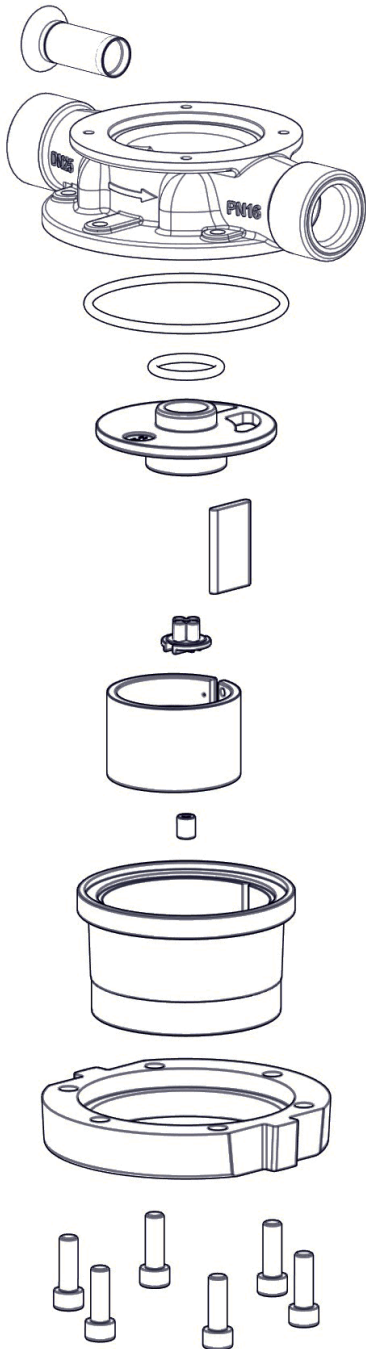
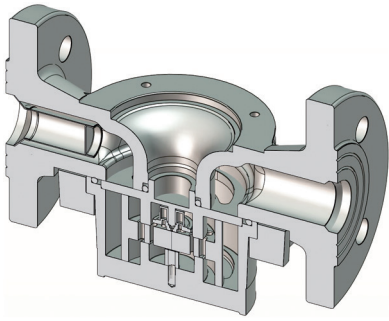

Inlet safety filter

Housing (no spare part)

O-ring big

O-ring small

Measuring chamber cover

Separating plate

Driver

Rotary piston

Guide roller

Measuring chamber

Measuring chamber Flange

Flange screws

# Project planning notes

## Burner

### Mounting on pressure side of pump

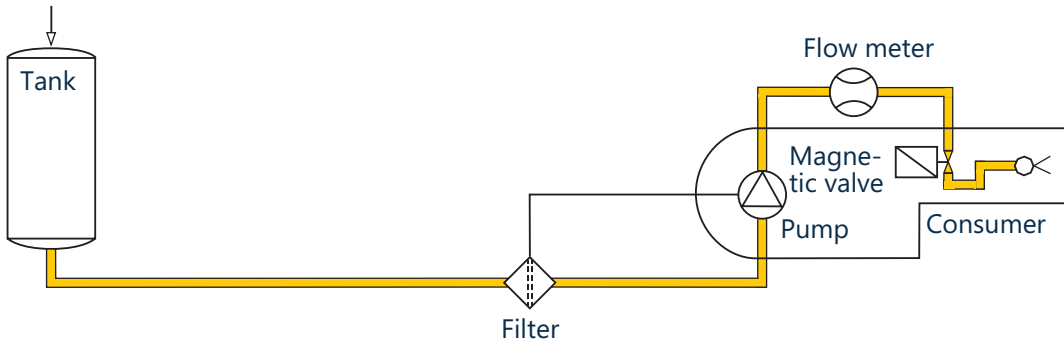

### Mounting on suction side of pump

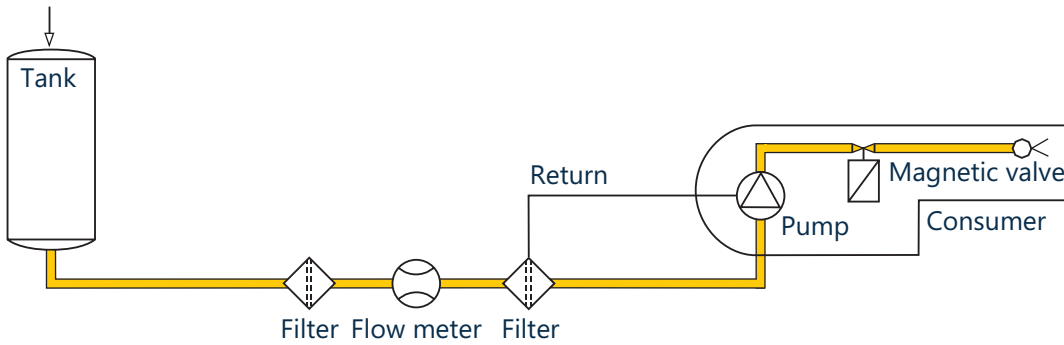

### Indicative values on power for burners

Burner		Flow meter		
Power	Flow rate heating fuel EL		Flow rate $Q_{min}...Q_{cont}$	Nominal diameter
	kg/h	l/h	l/h	DN
up to kW				
4000	336	400	10...400	15
10000	840	1000	30...1000	20
20000	1680	2000	75...2000	25
60000	5040	6000	225...6000	40
200000	16800	20000	750...20000	50

Formula for consumption in litres/hour:

Burner power in kW

Energy value of fuel in kWh/kg x density in kg/dm<sup>3</sup>

Example:

$$\frac{4000 \text{ kW}}{11.8 \text{ kWh/kg} \times 0.84 \text{ kg/dm}^3} = 4000 : 9.912 = 403 \text{ l/h}$$

# Engine

## Direct measurement

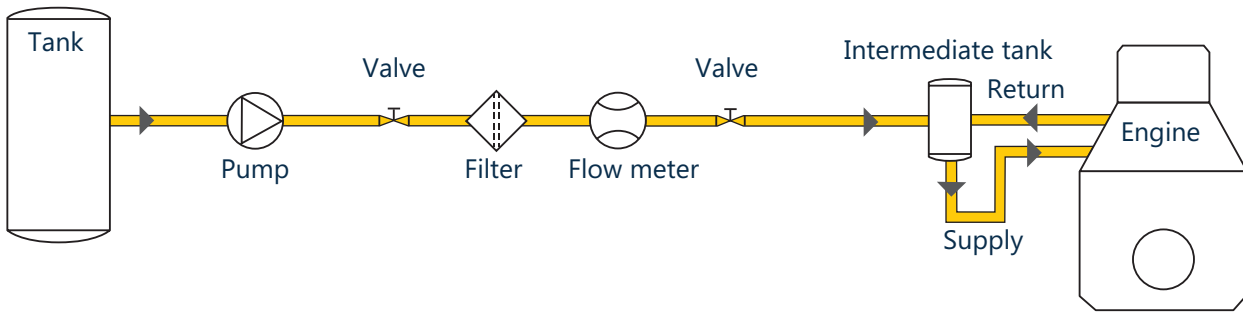

## Differential measurement

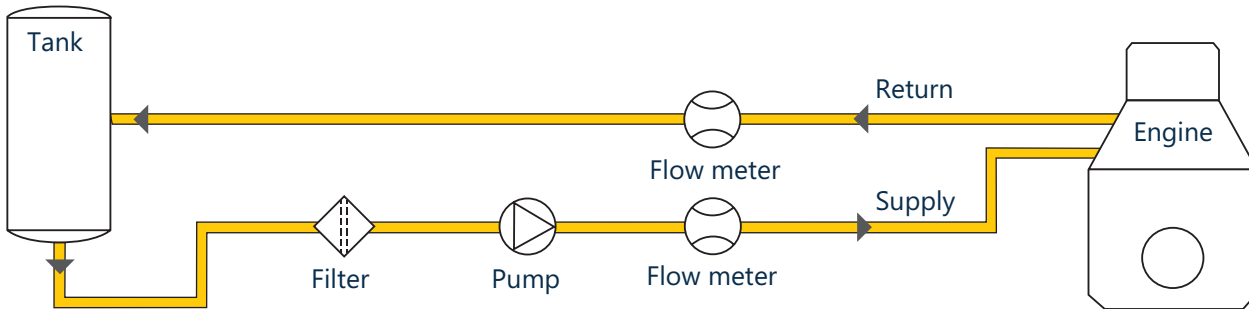

Engine		Flow meter <sup>1)</sup>	
Power	Diesel fuel consumption	Flow rate Q <sub>min</sub> ...Q <sub>cont</sub>	Nominal diameter
up to PS	up to kW	l/h	DN
2000	1470	400	15
5000	3680	1000	20
10000	7360	2000	25
30000	22000	6000	40
100000	73600	20000	50

1) For differential measurement the flow meter has to be selected according to the pump flow rate and the flow in the return pipe.

Formula:  $1 \text{ DIN-PS} = 0,736 \text{ kW}$      $1 \text{ kg Diesel at } 0,84 \text{ kg/dm}^3 = 1,19 \text{ l}$   
 $1 \text{ kW} = 1,36 \text{ DIN-PS}$

Rule of thumb: approx. 190 g Diesel / kWh correspond to 0,226 l/h/kW  
 approx. 140 g Diesel / PS correspond to 0,167 l/h/PS

## Sample calculation with direct and differential measurement

### ASSUMPTIONS:

- All Flow meter 1 % accuracy
- M/E consumption 4'000 l/hr
- A/E SL: 3'000 l/hr /
- RL: 2'600 l/hr
- 10'000 l/hr
- Circulation pump
- Accuracy M/E with A/E running
  - FM2: 1 % of 3'000 l/hr → 30 l/hr
  - FM3: 1 % of 2'600 l/hr → 26 l/hr
  - 30 + 26 l/hr = 56 of 400 l/hr
  - FM0: 1 % of 4'000 + 400 l/hr → 44 l/hr
  - Total accuracy of M/E = 44 + 56 = 100 of 4'000 l/hr

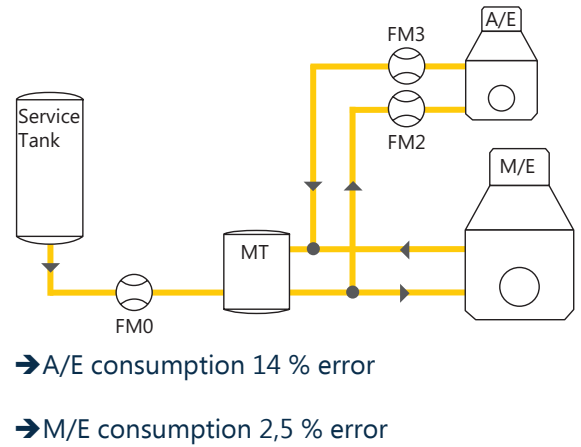

## Sample calculation with 2x differential measurement

### ASSUMPTIONS:

- All Flow meter calibrated in pair: (0.1% / 0.3% accuracy)
- M/E: SL: 10'000 l/hr
- RL: 6'000 l/hr
- A/E: SL: 3'000 l/hr
- RL: 2'600 l/hr
- Accuracy M/E with A/E running
  - FM2: 0.1% of 3'000 l/hr → 3.0 l/hr
  - FM3: 0.3% of 2'600 l/hr → 7.8 l/hr
  - 3.0 + 7.8 l/hr = 10.8 of 400 l/hr
  - FM0: 0.1% of 10'000 l/hr → 10.0 l/hr
  - FM1: 0.3% of 6'000 l/hr → 18.0 l/hr
  - Total accuracy of M/E = 10+18 = 28 of 4'000 l/hr

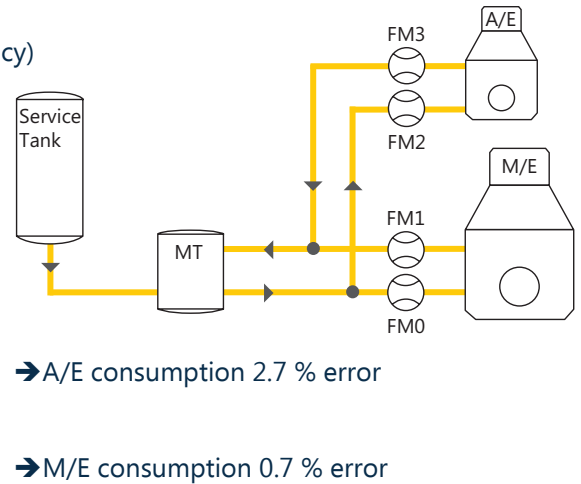

## Sample calculation for differential measurement

### ASSUMPTIONS:

- Standard calibration 1 % accuracy (CONTOIL® VZF II):
  - Supply (FM#0) 10'000 l/h ± 1 % = ±100 l/h
  - Return (FM#1) 10'000 l/h ± 1 % = ±100 l/h
  - **Max. difference** 2 % = 200 l/h
- Pair calibration 0.1 % + 0.3 % accuracy (CONTOIL® VZFA II):
  - Supply (FM#0) 10'000 l/h ± 0.1 % = ±10 l/h
  - Return (FM#1) 10'000 l/h ± 0.3 % = ±30 l/h
  - **Max. difference** 0.4 % = 40 l/h

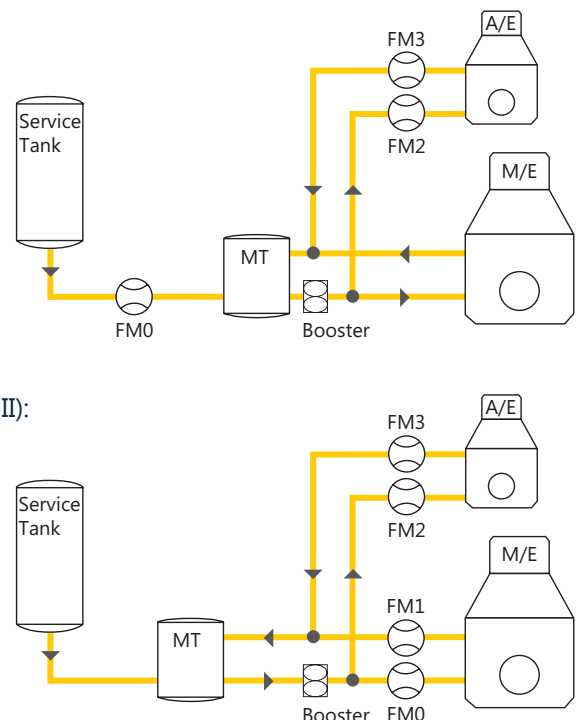

## Negative influencing factors

List of factors which can influence the performance of the flow meter negatively

### Medium

- Seawater
- Acid
- Cleaning products

### Mechanical

- Pulsating pressure
- Cat fines
- Pre-Filter mesh size

### Specification

- Dimension to small
- Over temperature

After any modification of the pipe system the system has to be cleaned / flushed **without** the flow meter installed to prevent any damage to the flow meter from any debris.

## Temperature compensation

The installation of temperature sensors at the flow meter positions is absolutely essential, without temperature compensation of the flow meter data, the error in the measurement can become extremely large, depending on the process conditions. As a rule of thumb we assume almost 1 % volume difference for each 10 °C temperature difference. (Usually there is a temperature difference between the oil in the supply line and in the return line.)

## Density compensation

If fuel oil consumption in mass need to be compared instead of volume, it is important to know that the mass is changing with the density, which itself is changing with the temperature. To obtain most precise measurement results, it is recommended to measure the online density on board. If there is no sensor available, you have to use the density which is given in each bunkering report and calculate volume values at different temperatures back to the corresponding mass values. However there are differences in HFO quality across the world and you should consider that the density mentioned on the bunkering report refers to the required specification.

The CONTOIL® VZF II is able to calculate the mass flow with a given density, adjusted by the measured medium temperature built in the flow meter.

These calculations are done according to DIN 51757.



# Installation

## Flow meter installation

Identify the flowmeter and ensure that the flowmeter is suitable for the intended process and conditions. Easy access for reading the flow meter and controlling the ancillary equipment is important. Provided that the arrow on the housing is in the direction of flow, the flow meter can be installed in any position without any special modifications. The electronic display unit is rotateable in 90° steps to the installed position.

### Exception: upside down installation.

Flow conditioners are not required.

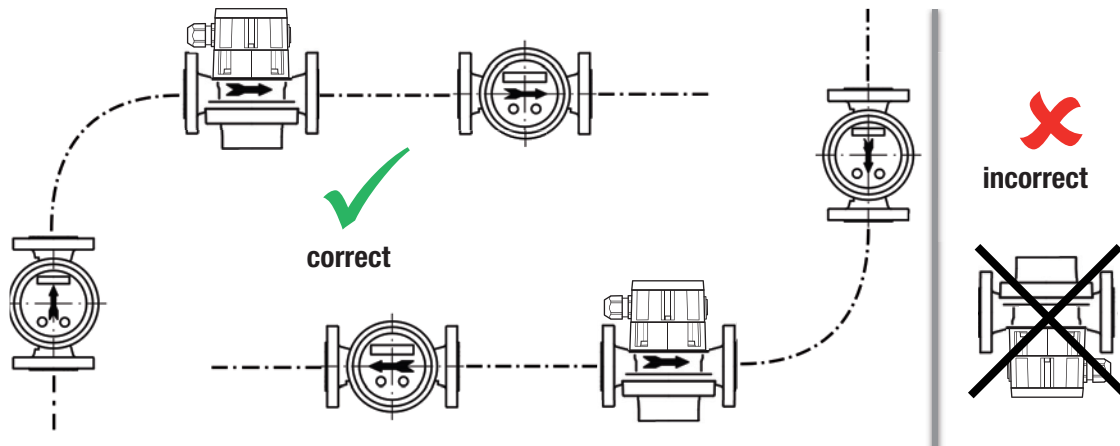

## Correct layout of flow meter and accessories

If the flow meter is used for viscosities higher than 5 mPa.s, or if it is mounted on the suction side of a pump, the pressure loss and the flow rate that can still be attained should be determined with the help of the pressure loss curves provided in this document. In addition, the pressure loss due to installed filters must be taken into consideration.

Select the flow meter and ancillaries according to the working conditions listed below:

- Flow rate (maximum expected application flow rate = maximum continuous flow rate of flow meter  $Q_{cont}$ )
- Material compatibility with medium
- Operating pressure and temperature
- Ambient temperature
- The flow meters must be selected according to the max. flow rate and not according to the pipe diameter. If necessary, adapt the pipework.

Pulsations at the flow meter shall be avoided to ensure a trouble free operation of the instrument.

## Dirt filter, safety filter

Filters are any way required in the system to protect engines and pumps to keep their performance and live time. For flow meters this is no different - that's why we recommend installing the flow meters (in flow direction) always directly after the filter. Some particles in the fuel are also from engine's wear and tear, that's why we also recommend a filter in the fuel return line. Usually basket type filters are best choice for the return line and automatic filters in the supply line. Major engine producers recommend a mesh size of 5 - 10  $\mu\text{m}$  (automatic filters), especially to filter out very abrasive cut fines. It is best for the flow meter to install it between this automatic filter and the engine. The maximum filter mesh size for a respective meter can be found in below table.

Examples of filter:

Maximum mesh width for filters		
Nominal diameter	Flow meter type	
	VZO/VZF II	VZOA/VZFA II
DN 15	0.250 mm	0.100 mm
DN 20	0.400 mm	0.100 mm
DN 25	0.400 mm	0.250 mm
DN 40	0.600 mm	0.250 mm
DN 50	0.600 mm	0.250 mm

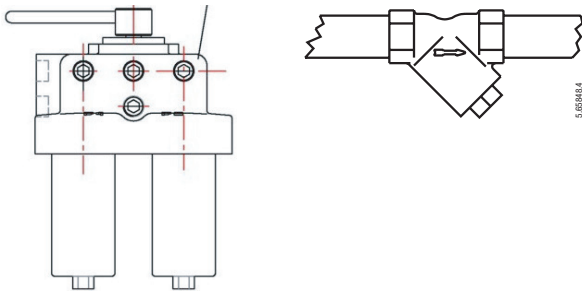

- The filter mounted in the meter inlet is only a safety filter and is too small to act as a dirt filter.
- If a dirt filter with the given mesh size is used, the safety filter in the meter inlet may be removed.

## Pulsation dampers

Engines and pumps can cause pressure peaks, which are transmitted throughout the whole fuel piping system and can cause damage to all parts in the system like filters, the viscosity control system, pumps themselves as well as the flow meters. It is recommended to install "pressure pulsation dampers" directly after the device, which is generating such pressure peaks (usually after the pump and after the engine).

## Pressure Loss

For the dimensioning of oil meters not only the flow rate, but also the pressure loss is important. All components in the fuel piping system and the piping layout itself cause a pressure loss. In general a higher flow and a higher viscosity cause a higher pressure loss over the flow meter. Piping bends, valves, reduction of pipes, as well as strainers and flow meters do also have a pressure loss, which must be taken into account when dimensioning the fuel supply system. Please check the pressure drop at each flow meter with the help of the pressure drop curves. For a pressure drop of more than 1 bar, it is recommended to use the next larger flow meter size.

- Ideally the flow meters are installed on the pressure side of the pump.

If the flow meters are on the suction side of the pump there is under pressure, which can cause out-gassing of the oil (1 % gas in the oil causes 1 % measurement failure).

Depending on the viscosity of the oil it is advised to check the pressure loss and decide if there is still enough pressure after the flow meter.

## Heat insulation

The electronic counter must not be insulated. This could cause its permitted temperature range to be exceeded.

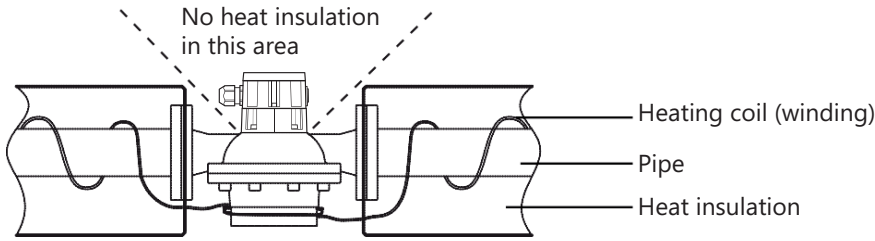

The permitted temperature ranges for the flow meter must be observed.

## Special requirements - ships

On ships, attention is required to ensure that the engine can continue to operate at full power even if there is heavy filter contamination or if the flow meter requires maintenance. A pressure switch or a manual valve can be used to switch over to the bypass and to draw attention for servicing. The engine then continues to operate without consumption measurements.

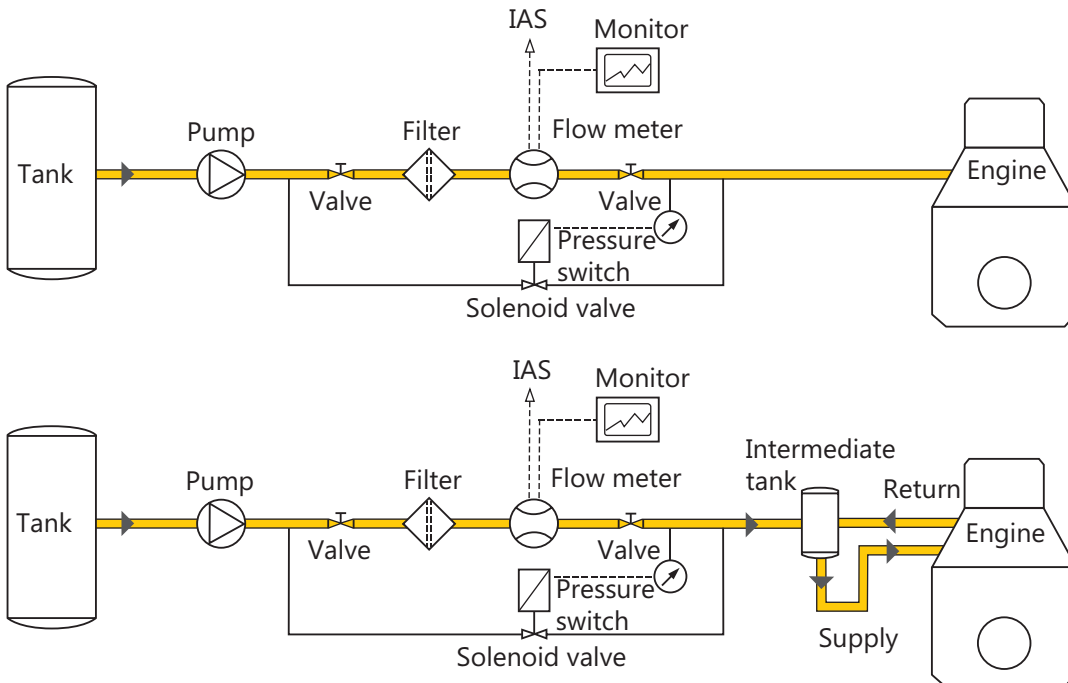

Ship classification societies require the installation of bypass pipes. The relevant regulations must be followed.

## Installation of the flow meter on the suction side of a pump

If the flow meter is installed on the suction side of a pump, consideration must be given to avoid air-intake or foam.

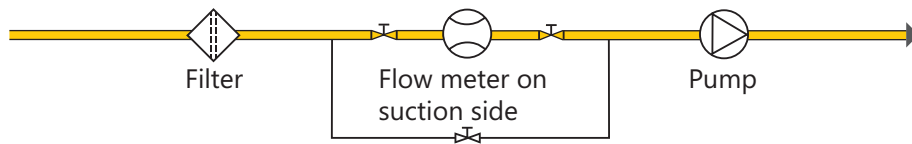

## Installation of the flow meter on the pressure side of a pump

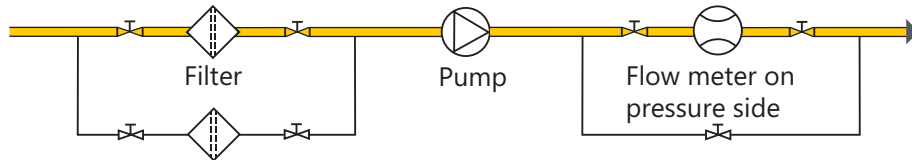

## Special requirements - filling and dosing units

For filling and dosing, the valve must be fitted between flow meter and discharge. The shorter the pipe section between valve and discharge, the higher the accuracy. Avoid water hammer if fast closing valve is installed.



## Display and user interface

### CONTOIL® VZF II

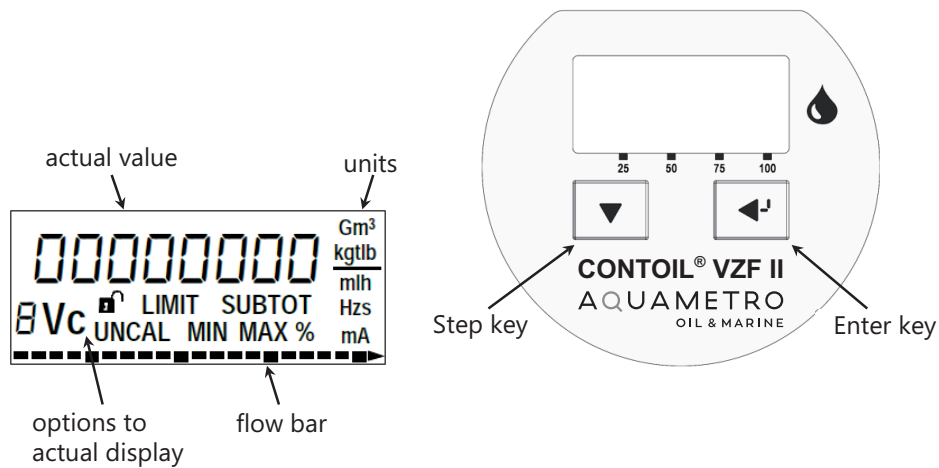

# Warranty, safety instructions

## Warranty Disclaimer

Aquametro Oil & Marine guarantees the quality of the product in the context of its General Terms of Business. The owner, operator or installer will be liable for the correct installation as well as the appropriate handling of the equipment upon its receipt.

- Please observe the application-, mounting- and operation-instructions.
- Use the unit exclusively for its designed purpose.
- Maintain the unit and service it according to prescriptions.
- Use accessories only if their applicability is technically safe.

## Safety rules and precautionary measures

The manufacturer accepts no responsibility if the following safety rules and precautions are disregarded.

- Modifications of the device implemented without preceding written consent from the manufacturer, will result in the immediate termination of product liability and warranty period.
- Installation, operation, maintenance and decommissioning of this device must be carried out by trained, qualified specialists, authorized by the manufacturer, operator or owner of the facility. The specialist must have read and understood these mounting- and operating-instructions and must follow the instructions here in.
- Check the voltage and the information on the type plate before installing the device.
- Check all connections, settings and technical specifications of peripherals which may be present.
- Open the housing or parts of housings, which electric or electronic components included, only when the electric power is turned off.
- Do not touch any electronic components (ESD sensitivity).
- Expose the system with respect to the mechanical load (pressure, temperature, IP protection, etc.), only to a maximum of the specified classifications.
- During operations that involve mechanical components of the system, release the pressure in the pipe system or reduce the temperature of the medium to a safe level for humans.
- None of the information stated here or elsewhere releases planners, installers and operators from their own careful and comprehensive assessment of the respective system configuration in terms of functional capability and operational safety.
- The local labor, safety laws and regulations must be adhered to.

# Certificates

Det Norske Veritas - German Lloyd Norway - Germany



Lloyds Register

United Kingdom



RRR

Russian River Register



RMRS

Russian Maritime Register of Shipping



PRS

Polish Register of Shipping





<b>SWITZERLAND:</b>	<b>Aquametro Oil &amp; Marine AG, Therwil</b>	<b>info@aquametro-oil-marine.com</b>	<b>www.aquametro-oil-marine.com</b>
<b>CHINA:</b>	Aquametro Oil & Marine (CHINA) PTE. LTD., Singapore	info@aquametro-oil-marine.cn	www.aquametro-oil-marine.cn
<b>GERMANY:</b>	Aquametro Oil & Marine GmbH, Rostock	info@aquametro-oil-marine.de	www.aquametro-oil-marine.de
<b>INDIA:</b>	Aquametro Oil & Marine Rep. Office, Mumbai	info@aquametro-oil-marine.in	www.aquametro-oil-marine.in
<b>JAPAN:</b>	Aquametro Oil & Marine Rep. Office, Tokyo	info@aquametro-oil-marine.jp	www.aquametro-oil-marine.jp
<b>KOREA:</b>	Aquametro Oil & Marine Korea LTD., Busan	info@aquametro-oil-marine.kr	www.aquametro-oil-marine.kr
<b>SINGAPORE:</b>	Aquametro Oil & Marine (S.E.A.) PTE. LTD., Singapore	info@aquametro-oil-marine.sg	www.aquametro-oil-marine.sg
<b>UAE:</b>	Aquametro ME JLT, Dubai / UAE	info@aquametro-oil-marine.ae	www.aquametro-oil-marine.ae